

# Reversible Cooling Fans for Radiator Cleaning

Many modern industrial and agricultural machines including excavators, wheelloaders, bulldozers and tractors use multiple radiators and have a huge need for cooling air. In dusty working environments, dirt and dust particles are drawn into the radiators and intake screens entrapping dust. This leads to reduced efficiency, overheated fluids in engine, gearbox and hydraulic systems and significantly reduced air-conditioning performance.



## Flexxaire Radiator Cleaning System

With fast pitch reversing, in under one second, the Flexxaire Fan purges debris from the radiator, effectively cleaning the radiator system. This ensures your radiator is kept clean and operational at all times. It can be programmed to purge at automatic intervals or manually with the touch of a button.

The Flexxaire Variable Pitch Engine Cooling Fan System provides total control of airflow, maximizes engine performance, saves fuel, and is robustly built and maintenance free.

## Benefits

- Keeps your radiator free and clear to increase efficiency and minimize operating downtime.
- With optimized variable air intake, your engine saves fuel and horsepower each hour of operation.
- No shutdown for manual radiator cleaning.
- Reduce the likelihood of fire in the engine department.
- Cleaning on demand for extra unscheduled purging.



Reversing happens at full speed by hydraulic or pneumatic actuation of the internal cylinder, rotating the fan blades instantly from a working position, over the neutral, into reversing and back.

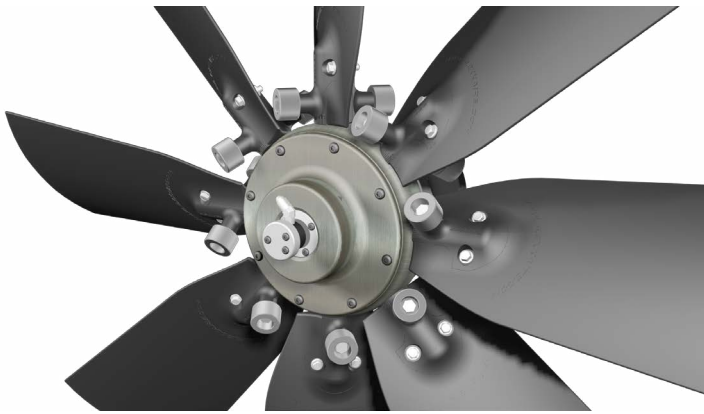

## Reversible Fan Blades

Flexxaire's reversible fan blades are designed and built for extreme conditions and high performance. High quality glass filled PAG (nylon) material allows for high temperature ranges from  $-40^{\circ}\text{C}$  to  $110^{\circ}\text{C}$  as well as high tip speed of up to 6100 m/min.

**The design of the blade shape is optimized to deliver maximum airflow and high static pressures needed to meet Tier IV emission requirements.**

## Variable Pitch Engine Cooling Hub

Flexxaire's in motion variable pitch hub allows the fan blade pitch to be adjusted at any fan speed.

All hub components are machined from solid material to ensure perfect balance without any voids or porosity in material structure. All joints are sealed with high-quality O-rings. The mechanical spring loaded fail-safe feature ensures maximum airflow if control is lost. Perfect Pitch Sensor provides accurate pitch feedback and is designed to last longer than the engine – operating up to 20Gs of vibration, from  $-40^{\circ}$  to  $120^{\circ}\text{C}$  temperatures, and exposure to debris and caustic fluids.

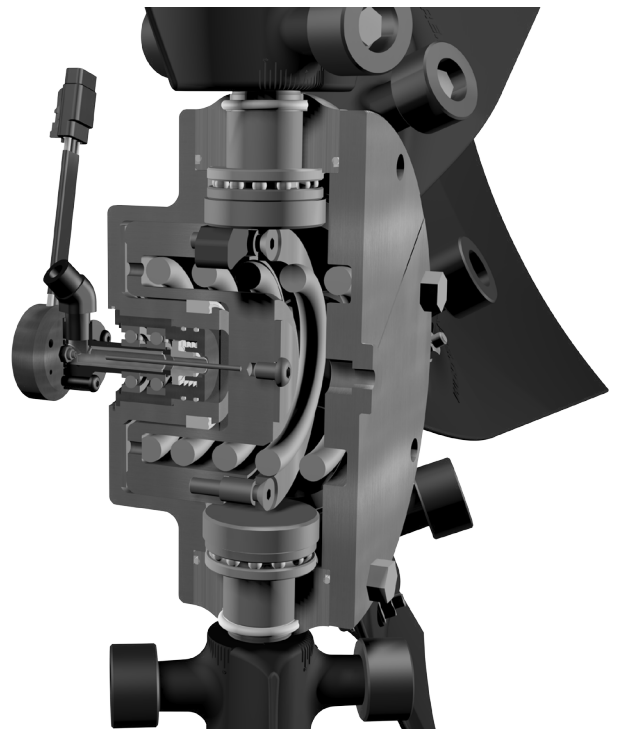

## Controls

Flexxaire controls are flexible, feature rich, robust and integrate seamlessly with onboard electronics. The system can be as simple as reversing the airflow or as complex as temperature driven pitch control. We provide turn-key solutions or assist you to integrate our system into an existing controller.

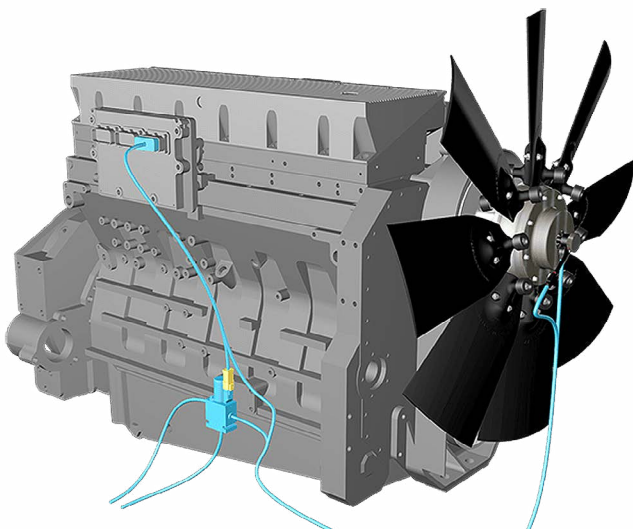

**FLEXXAIRE**